



PASAMANOS

ENSAMBLE

PASAMANOS VIDRIO TEMPLADO

ALTERNATIVAS DE ARMADO

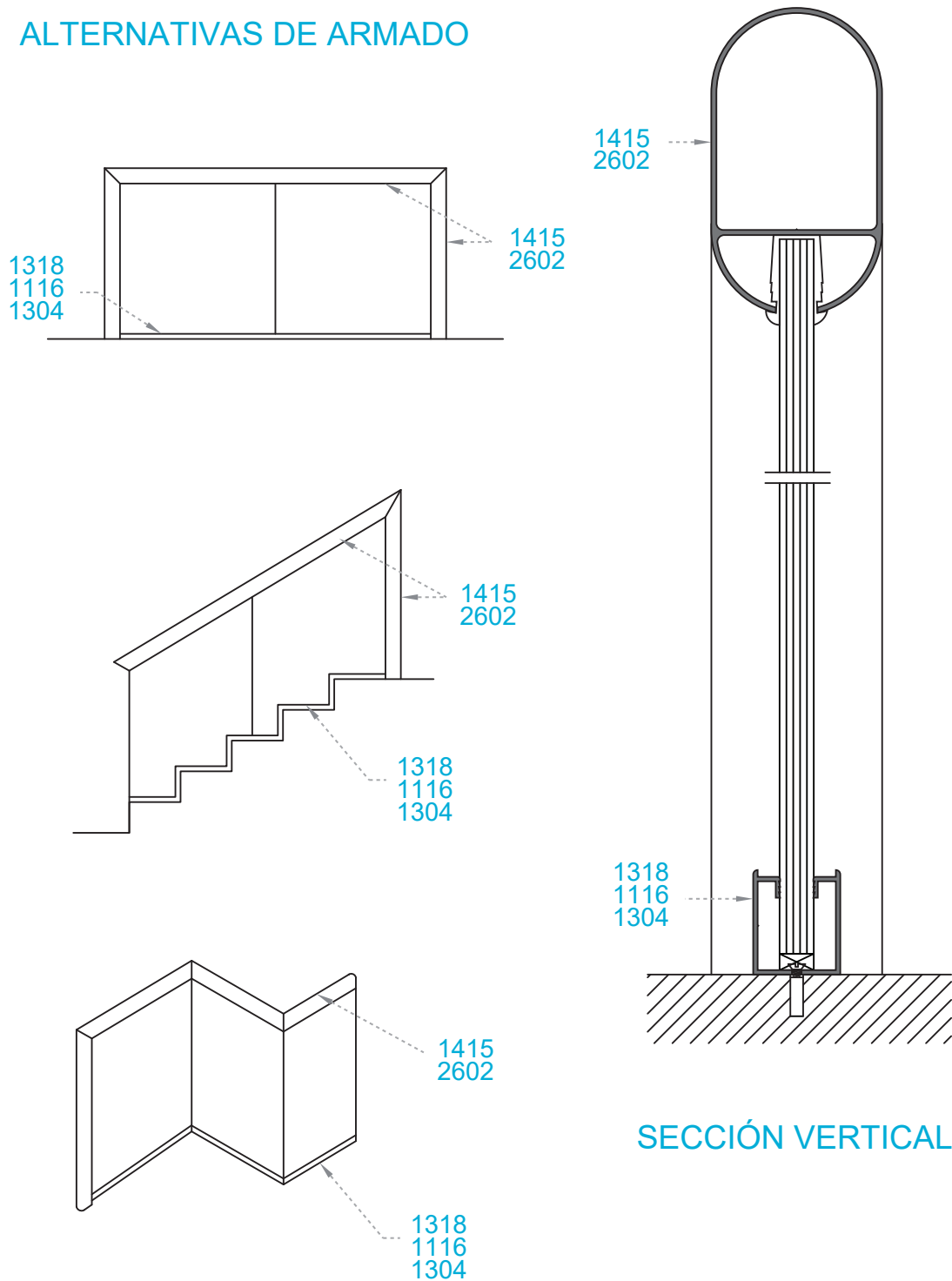



PASAMANOS

ENSAMBLE

PASAMANOS STANDAR (1 1/2)

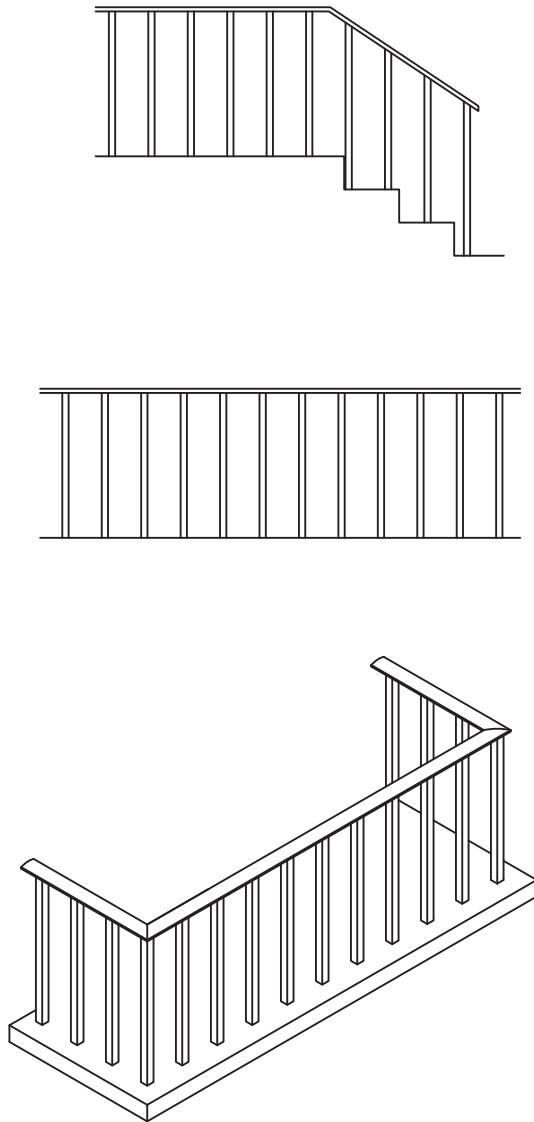

ALTERNATIVAS DE DISEÑO

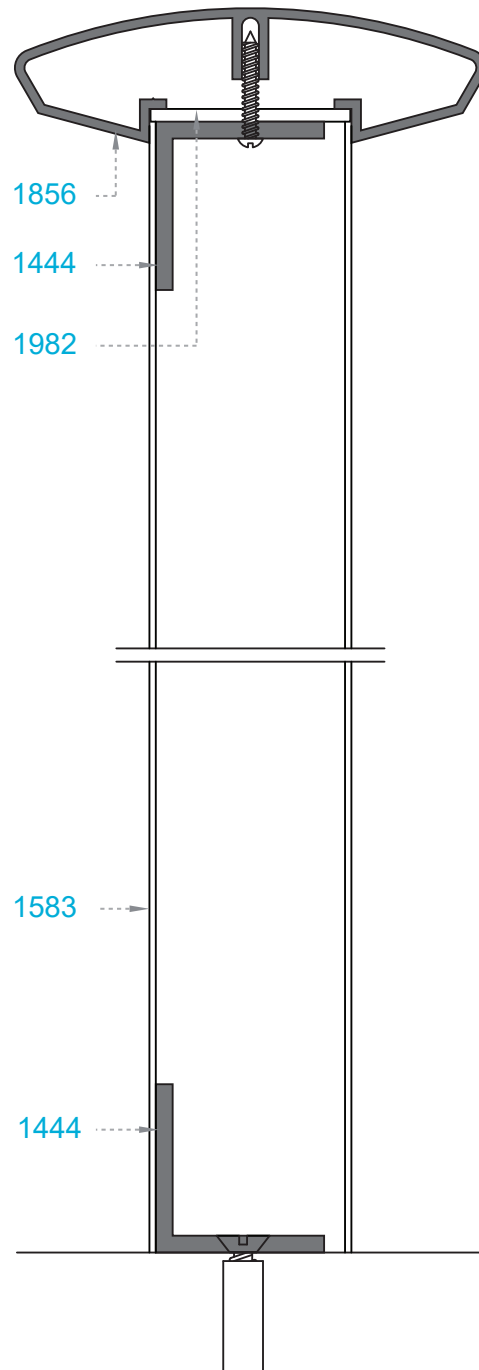

SECCIÓN VERTICAL



Pasamanos

Escala: 1:1
Medida: Milímetros

REFERENCIAS

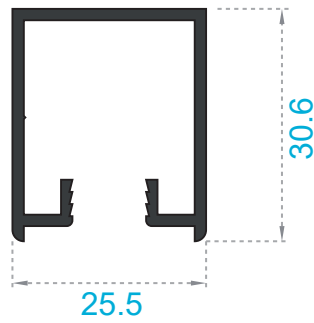

| Referencia | Peso |
|------------|------------|
| 1116 | 0.421Kg/m. |

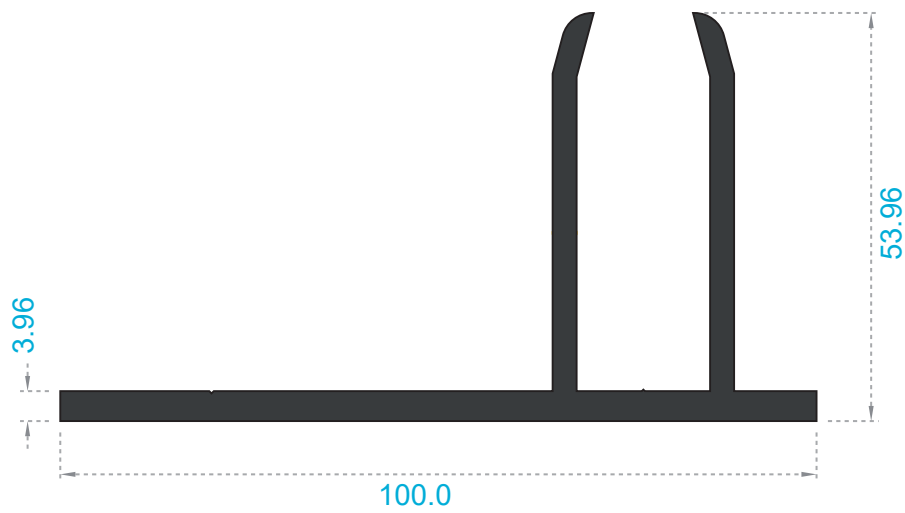

| Referencia | Peso |
|------------|------------|
| 1318 | 1.929Kg/m. |



Pasamanos

Escala: 1:1
Medida: Milímetros

REFERENCIAS

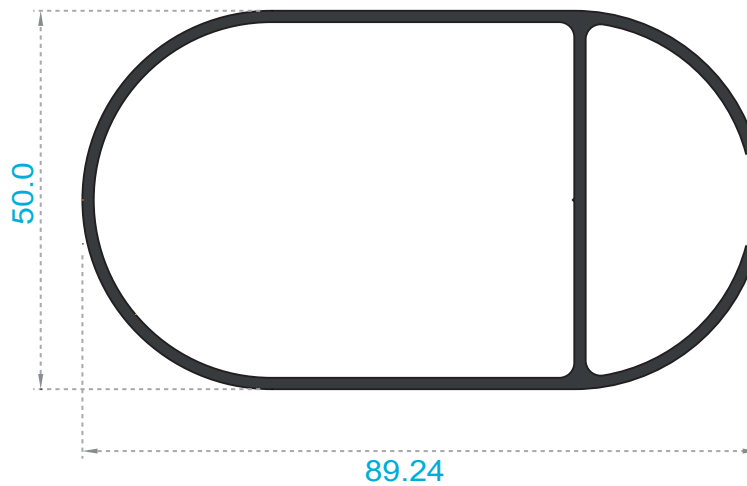

| Referencia | Peso |
|------------|------------|
| 1415 | 1.096Kg/m. |

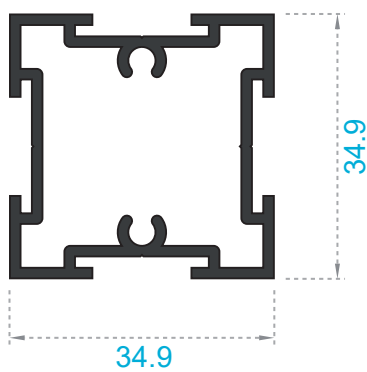

| Referencia | Peso |
|------------|------------|
| 1497 | 0.727Kg/m. |

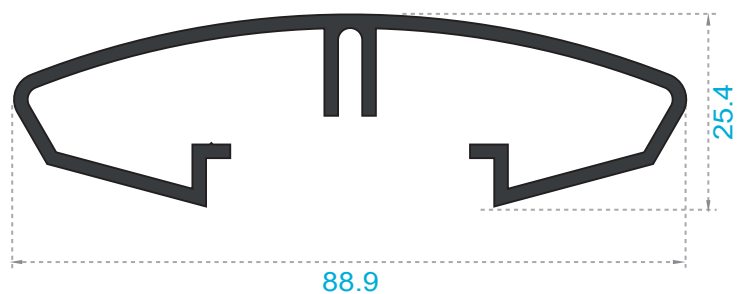

| Referencia | Peso |
|------------|------------|
| 1856 | 0.947Kg/m. |



Pasamanos

Escala: 1:1
Medida: Milímetros

REFERENCIAS

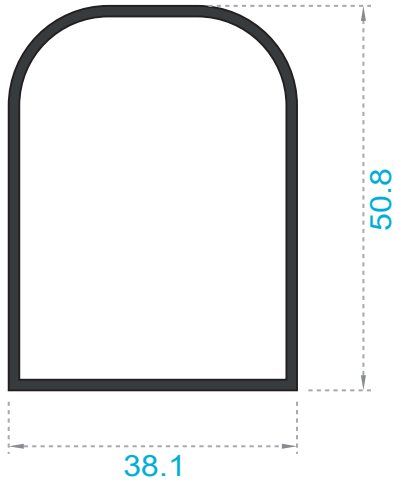

| Referencia | Peso |
|------------|------------|
| 2393 | 0.613Kg/m. |

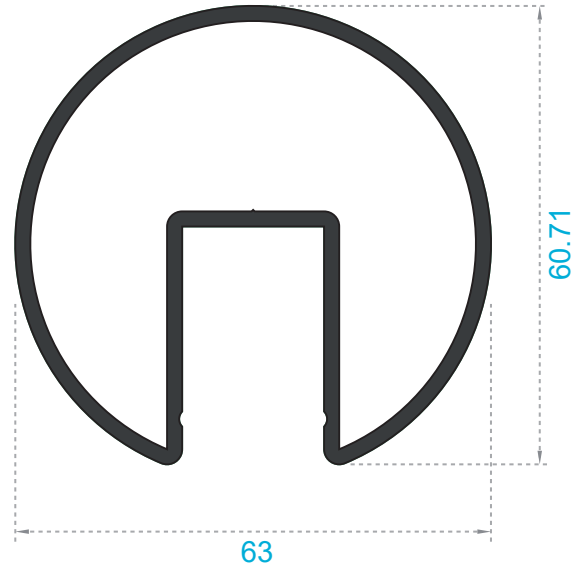

| Referencia | Peso |
|------------|------------|
| 2602 | 1.365Kg/m. |

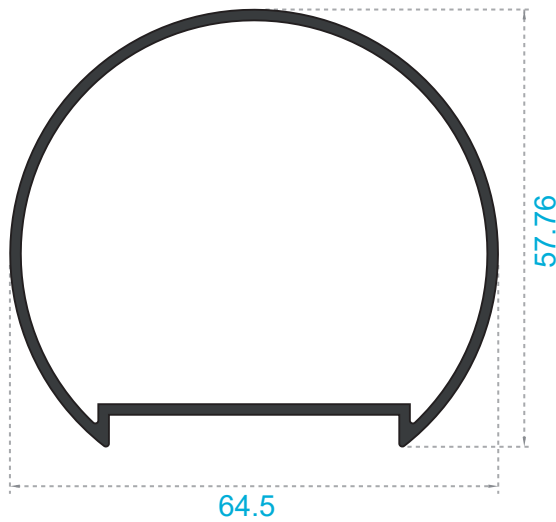

| Referencia | Peso |
|------------|------------|
| 2823 | 0.769Kg/m. |