



CATÁLOGO DE SISTEMAS

VERSIÓN 2024

*LAS MEDIDAS DE REFERENCIAS DE LAS IMAGENES SON EN MILIMETROS

VCR100

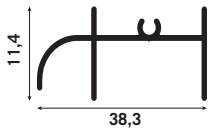

3763
VENTANA

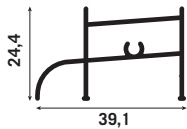

3764
VENTANA



3765
VENTANA

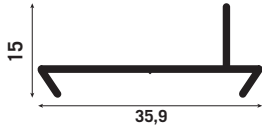

3766
VENTANA



3767
VENTANA

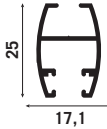

3768
VENTANA

*LAS MEDIDAS DE REFERENCIAS DE LAS IMAGENES SON EN MILIMETROS

LOUVERS



1419
JAMBA
TRIANGULAR



2020
VENTILACION
INTEGRAL



2956
ELIPSE

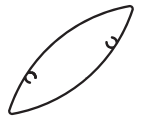

3027
ELIPSE



3143
CORTASOLES



3296
PERSIANA
TUBULAR FIJA



3334
MUEBLES DE
COCINA

CORTASOLES

*LAS MEDIDAS DE REFERENCIAS DE LAS IMAGENES SON EN MILIMETROS



3043
CORTASOL



3044
PERFIL TAPA CORTASOL



3475
CORTASOL

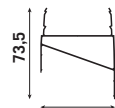

3476
CORTASOL

VARIOS

*LAS MEDIDAS DE REFERENCIAS DE LAS IMAGENES SON EN MILIMETROS



1184
REMATE
SIMPLE
REVESTIMIENTO

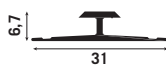

1187
PERFIL PARA
ENSAMBLE
REVESTIMIENTO

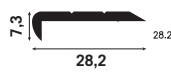

1233
MOLDURA
DE 28.2 MM
O 11/8



1234
MOLDURA
DE 21.4 MM
O 27/32

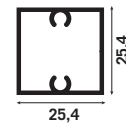

1285/1855
TUBO DE 1 X 1
CON TORNILLO



1747
U DE 1/2 X
1/2
ECONOMICA



1983
DOBLE U



1984
U CON
ALETA



2034
U DE
3/8 X 1/2



2044
MARCO
PARA CUADROS



2168
U DE 1 X 1/2



2490
CUADRICULA
DECORATIVA

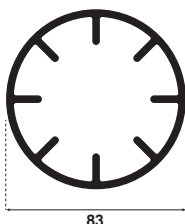

2574
ASPERSOR DE 3



2734
FILO DE
ALFOMBRA
28 MM



2735
FILO DE ALFOMBRA
20 MM

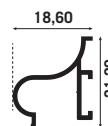

3163
PECHO
PALOMA

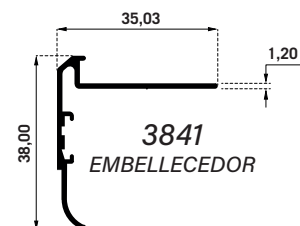

3841
EMBELLECEDOR

*LAS MEDIDAS DE REFERENCIAS DE LAS IMAGENES SON EN MILIMETROS

COURTAIN WALL

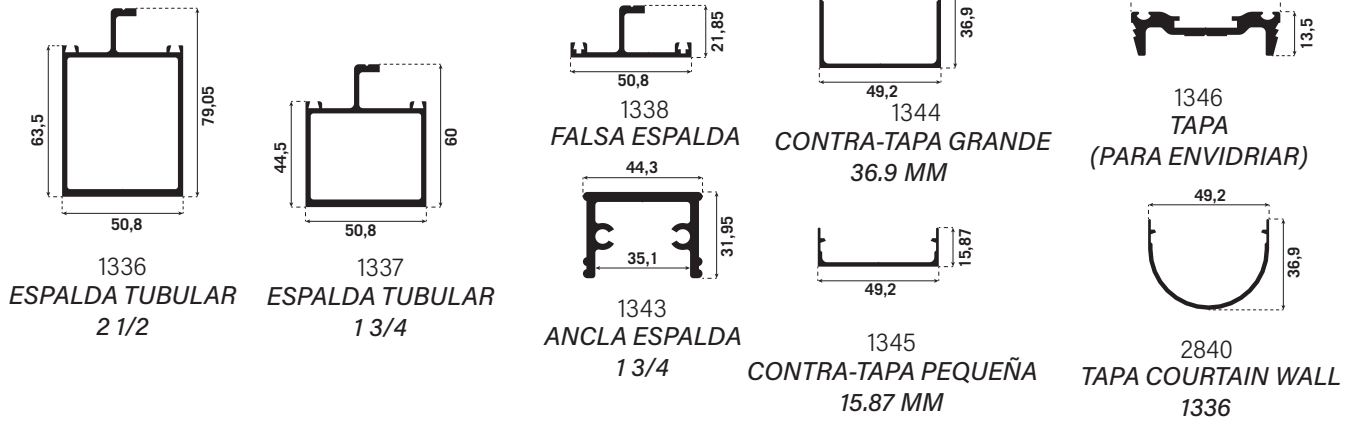

MURO CORTINA S-530

*LAS MEDIDAS DE REFERENCIAS DE LAS IMAGENES SON EN MILIMETROS

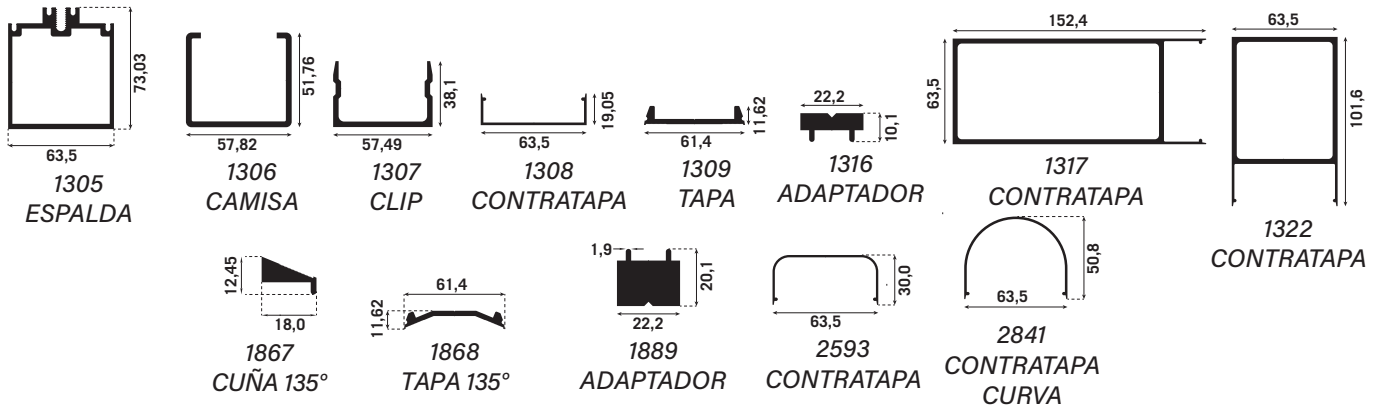

PASAMANOS

*LAS MEDIDAS DE REFERENCIAS DE LAS IMAGENES SON EN MILIMETROS

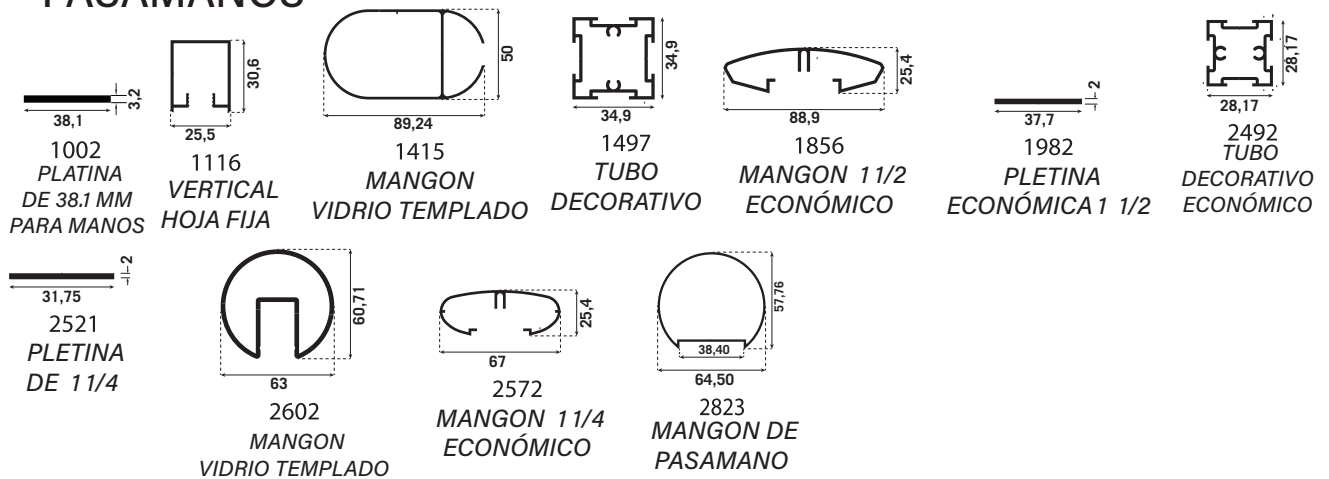

JUNQUILLOS - REVESTIMIENTOS

*LAS MEDIDAS DE REFERENCIAS DE LAS IMAGENES SON EN MILIMETROS

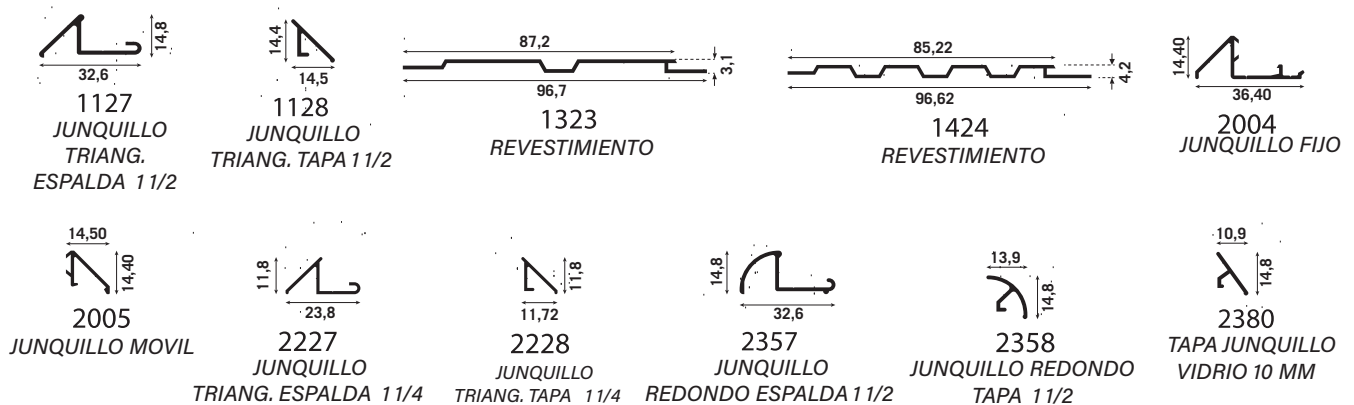

*LAS MEDIDAS DE REFERENCIA DE LAS IMAGENES SON EN MILIMETROS

PUERTA CORREDIZA ESTANDAR

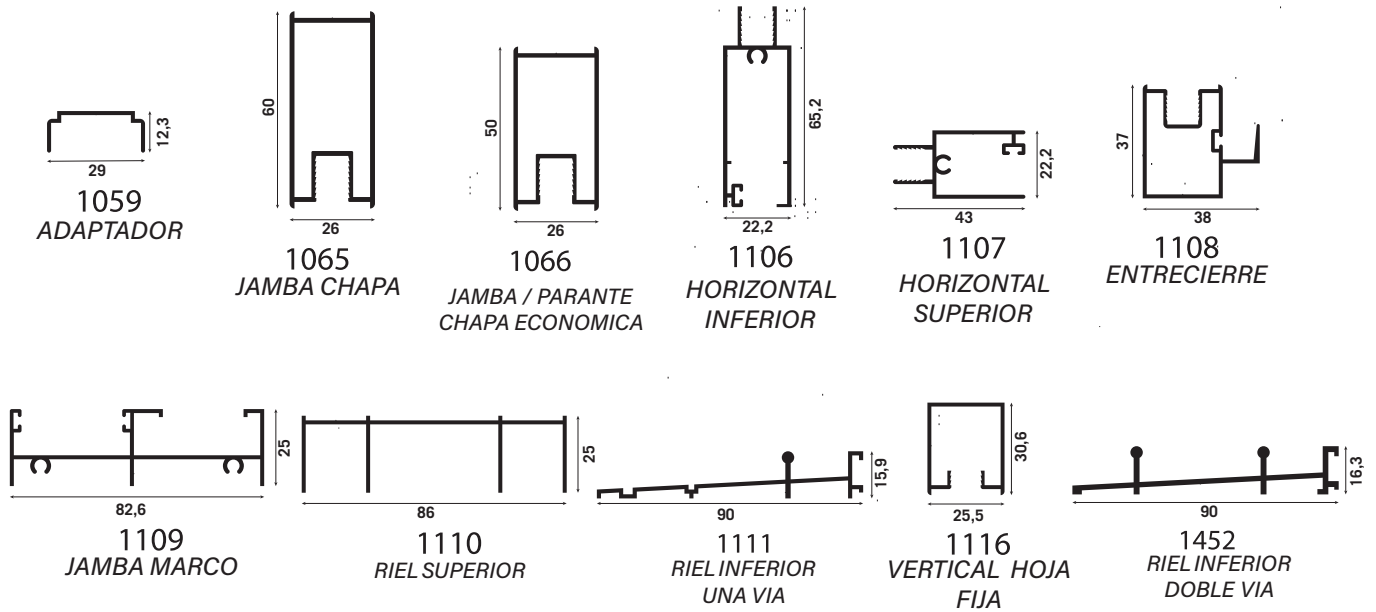

*LAS MEDIDAS DE REFERENCIA DE LAS IMAGENES SON EN MILIMETROS

PUERTA CORREDIZA ECONÓMICA

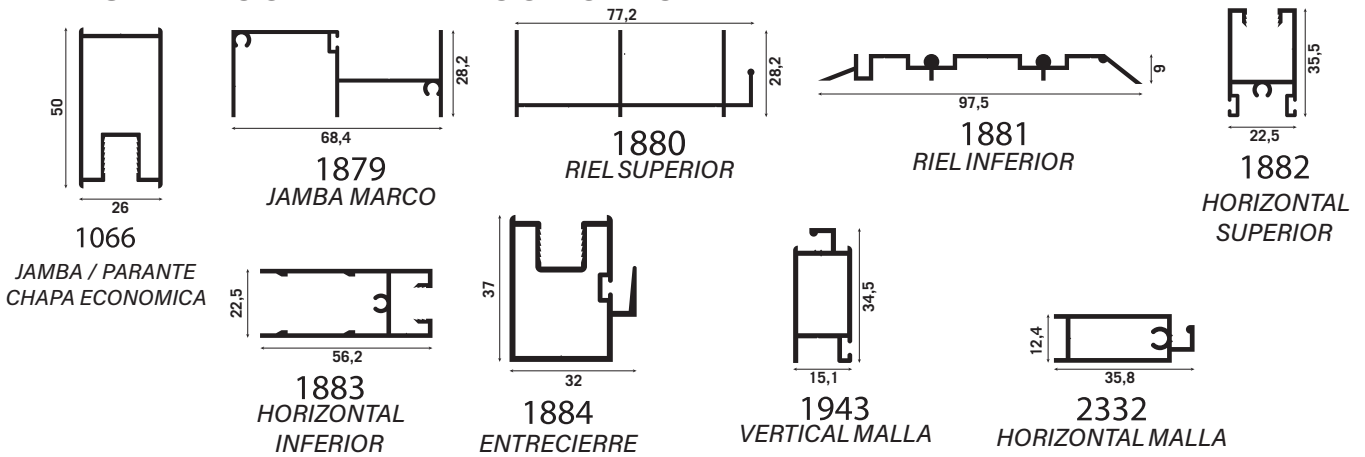

*LAS MEDIDAS DE REFERENCIA DE LAS IMAGENES SON EN MILIMETROS

ÁNGULOS Y T

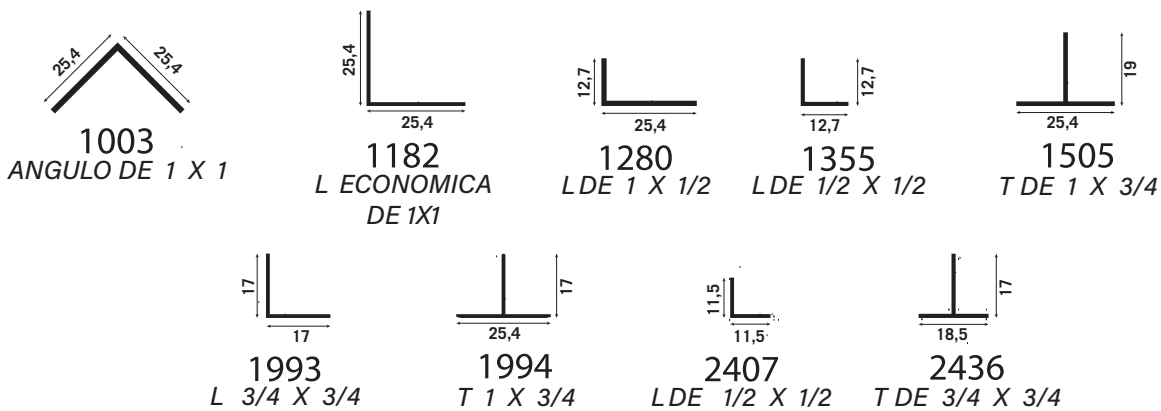

ANTENAS

*LAS MEDIDAS DE REFERENCIA DE LAS IMAGENES SON EN MILIMETROS

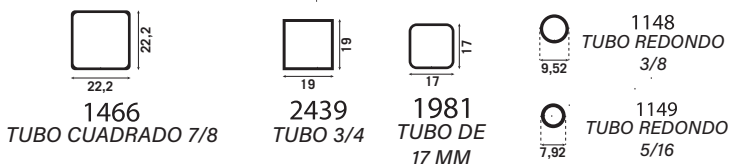

TRANSPORTADOR

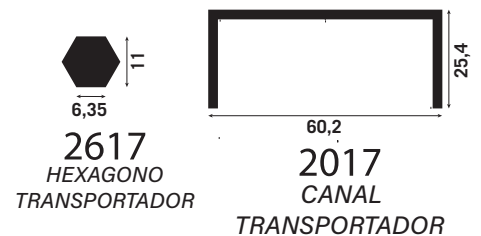

SISTEMA T-45 LITE

*LAS MEDIDAS DE REFERENCIA DE LAS IMAGENES SON EN MILIMETROS

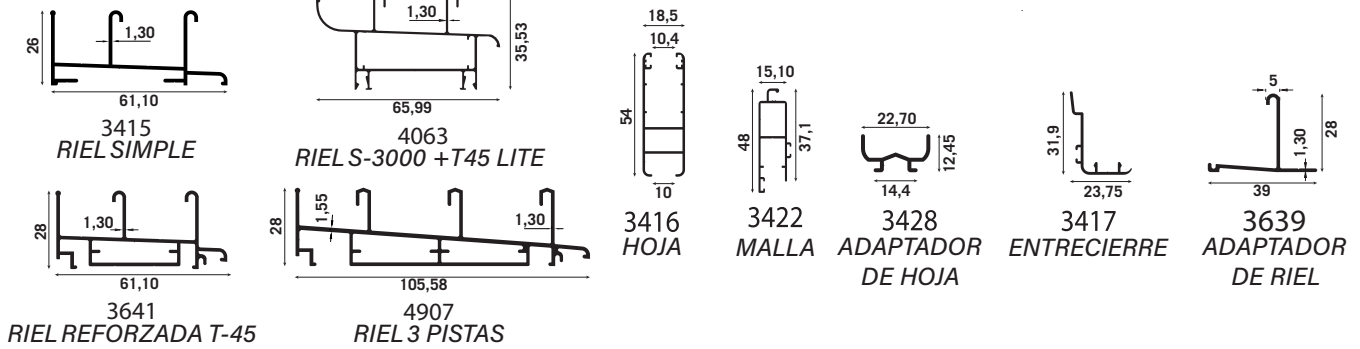

SISTEMA T-45

*LAS MEDIDAS DE REFERENCIA DE LAS IMAGENES SON EN MILIMETROS

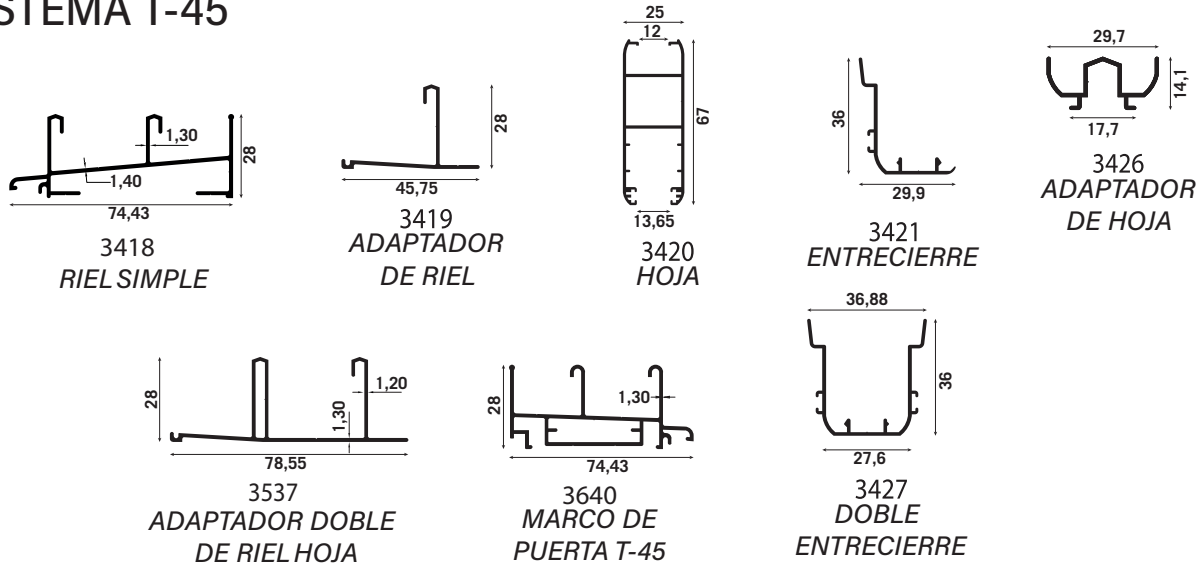

S4200

*LAS MEDIDAS DE REFERENCIA DE LAS IMAGENES SON EN MILIMETROS

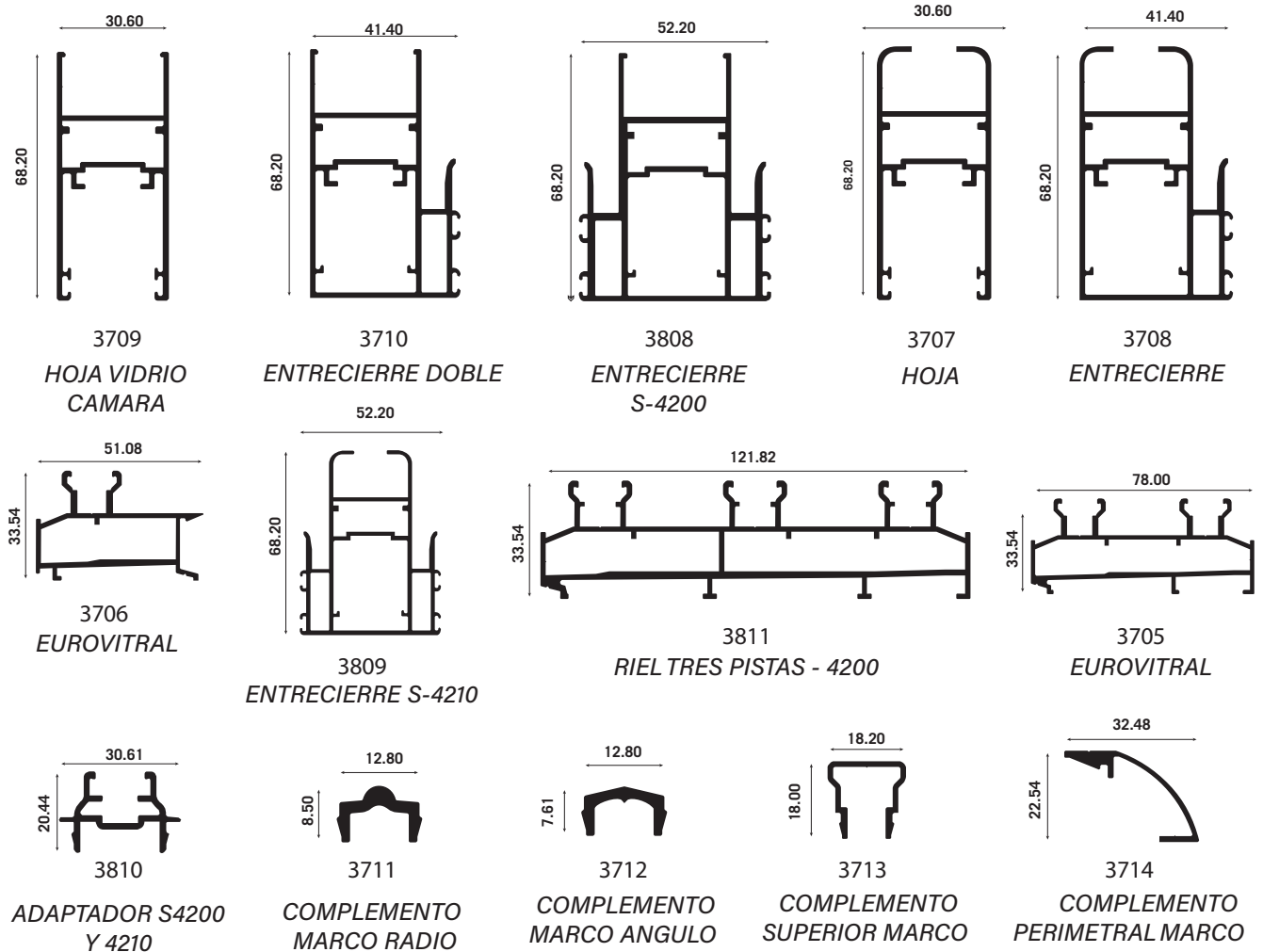

VENTANA CORREDIZA 4 PERFILES

*LAS MEDIDAS DE REFERENCIA DE LAS IMAGENES SON EN MILIMETROS

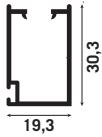

1283
VERTICAL ABIERTO
ESTANDAR

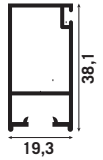

1388
VERTICAL
CERRADO ESTANDAR



1523
RIEL SUP E
INF ESTANDAR

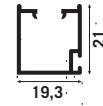

1573
VERTICAL
ABIERTO
ECONOMICO

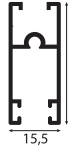

1671
HORIZONTAL
ECONOMICO

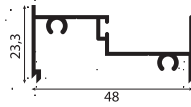

1823
JAMBA MARCO
ESTANDAR



1825
VERTICAL
CERRADO ECONOMICO

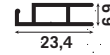

2331
MALLA CORREDIZA
ECONOMICA

VENTANA CORREDIZA 7 PERFILES

*LAS MEDIDAS DE REFERENCIA DE LAS IMAGENES SON EN MILIMETROS

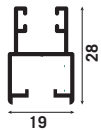

2231
VERTICAL

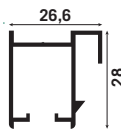

2232
ENTRECIERRE FIJO



2233
HORIZONTAL
ESTANDAR

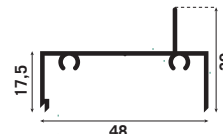

2234
JAMBA MARCO

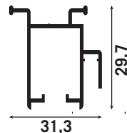

2235
ENTRECIERRE MOVIL

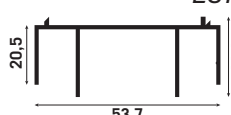

2237
RIEL SUPERIOR

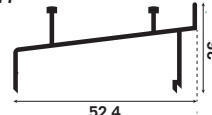

2238
RIEL INFERIOR

SISTEMA CP-70

*LAS MEDIDAS DE REFERENCIA DE LAS IMAGENES SON EN MILIMETROS

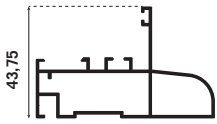

3933
CUERPO FIJO

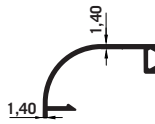

3934
JUNQUILLO FIJO

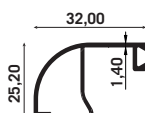

3935
JUNQUILLO

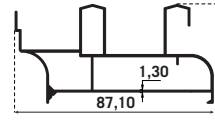

4367
ADAPTADOR RIEL
2 PISTAS



3937
ENTRECIERRE

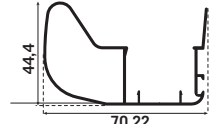

3938
ENTRECIERRE
CON ALETA

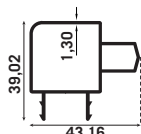

4368
ENCUENTRO
ESQUINERO

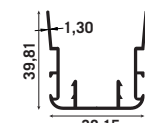

4369
DOBLE ENTRECIERRE

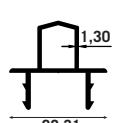

4372
ADAPTADOR
DE HOJA

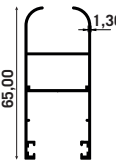

4064
HOJA

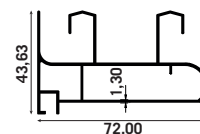

4933
RIEL 2 PISTAS

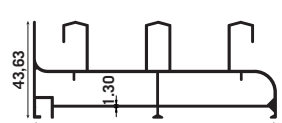

4934
RIEL 3 PISTAS

VENTANA PROYECTABLE

*LAS MEDIDAS DE REFERENCIA DE LAS IMAGENES SON EN MILIMETROS

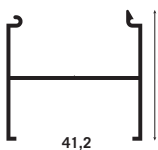

2924
AUMENTO VENTANA
PROYECTABLE

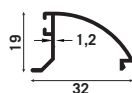

2312
JUNQUILLO
REDONDO

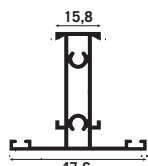

1382
MARCO DOBLE

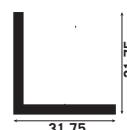

1444
L 1 1/4 X 1 1/4

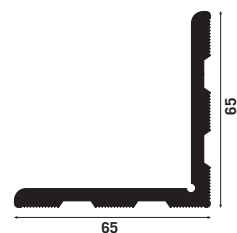

1449
ANCLA

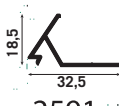

2591
JUNQUILLO
VIDRIO CAMARA

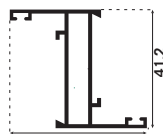

1384
HOJA



1383
JUNQUILLO

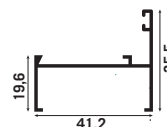

1385
MARCO

VENTANA CORREDIZA 6 PERFILES

*LAS MEDIDAS DE REFERENCIA DE LAS IMAGENES SON EN MILIMETROS

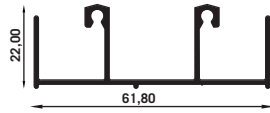

3740
RIEL SUPERIOR



3741
RIEL INFERIOR

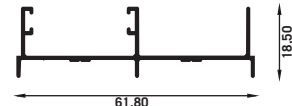

3742
JAMBA MARCO

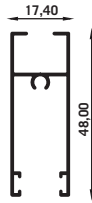

3743
HORIZONTAL
DE HOJA

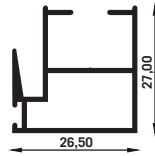

3744
ENTRECIERRE

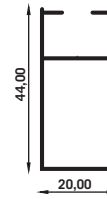

3745
VERTICAL
DE HOJA

VENTANA CORREDIZA 2000

*LAS MEDIDAS DE REFERENCIA DE LAS IMAGENES SON EN MILIMETROS



2312
JUNQUILLO
REDONDO

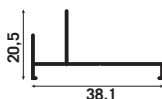

2603
RIEL SUPERIOR

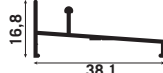

2604
RIEL INFERIOR



2608
HORIZONTAL
SUPERIOR
V/C 7025-2



2610
VERTICAL
V/C 7025-2000

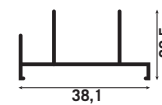

2611
CABEZAL V/C
7025-2000

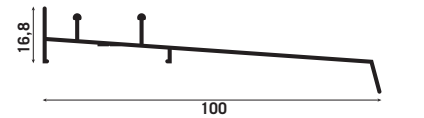

2796
RIEL DOBLE INF. ALFAJIA

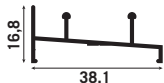

2612
BASE V/C
7025-2000



2623
JAMBA
MOVIL

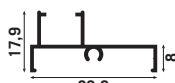

2624
RIEL INFERIOR



2625
HORIZONTAL
SUPER-INFER.
MOVIL

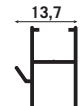

2626
ENTRECIERRE

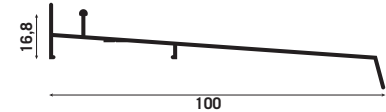

2797
RIEL SIMPLE INF ALFAJIA

VENTANA FIJA ESTANDAR

*LAS MEDIDAS DE REFERENCIA DE LAS IMAGENES SON EN MILIMETROS

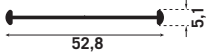

1027
MULLON



1026
JUNQUILLO
SIN FELPERO



2236
JUNQUILLO
CON FELPERO

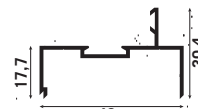

2229
HORIZONTAL

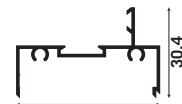

2230
VERTICAL

VENTAJA FIJA ECONÓMICA

*LAS MEDIDAS DE REFERENCIA DE LAS IMAGENES SON EN MILIMETROS



1026
JUNQUILLO
SIN FELPERO



1808
HORIZONTAL

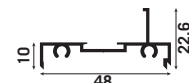

1809
VERTICAL

TUBOS CUADRADOS

*LAS MEDIDAS DE REFERENCIA DE LAS IMAGENES SON EN MILIMETROS

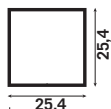

1286/1714/2036
TUBO DE 1 X 1
SIN TORNILLO



1386/1583/2836/2863
TUBO 1 1/2

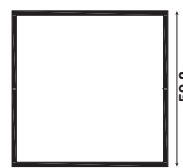

1015/1852
TUBO DE 2 X 2
CUADRADO

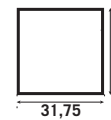

1373/1854
TUBO DE
1 1/4 X 1 1/4

*LAS MEDIDAS DE REFERENCIA DE LAS IMAGENES SON EN MILIMETROS

S3000 PUERTA BATIENTE DOBLE

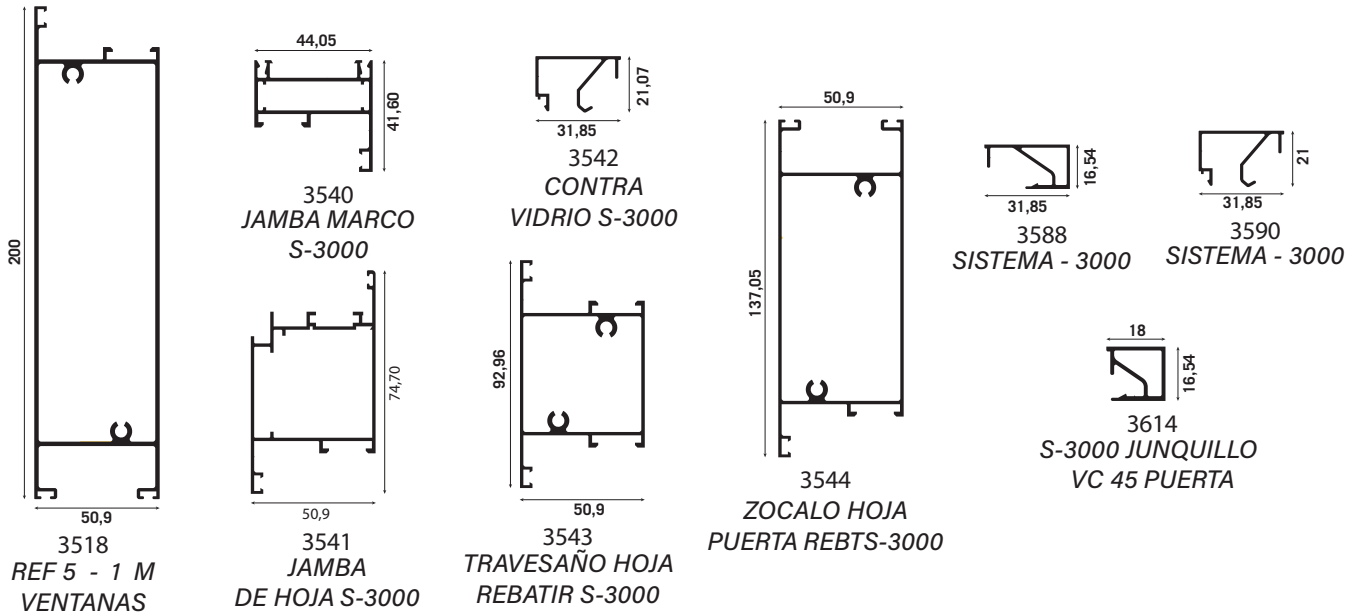

*LAS MEDIDAS DE REFERENCIA DE LAS IMAGENES SON EN MILIMETROS

S3000 VENTANA PROYECTANTE

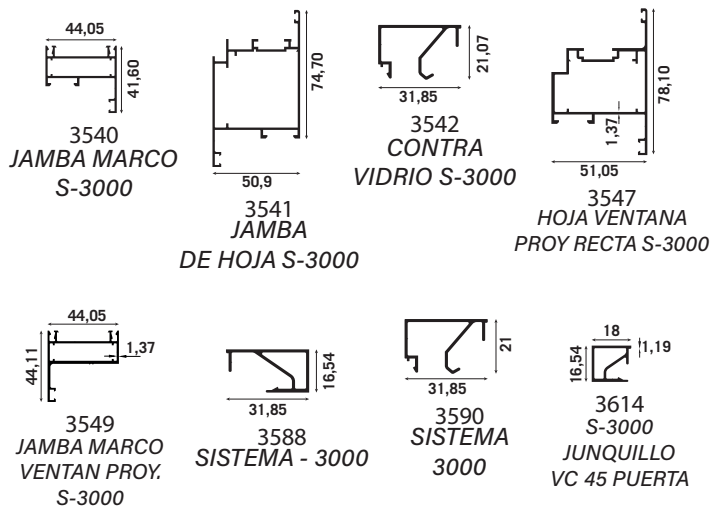

*LAS MEDIDAS DE REFERENCIA DE LAS IMAGENES SON EN MILIMETROS

S3000 CUERPO FIJO

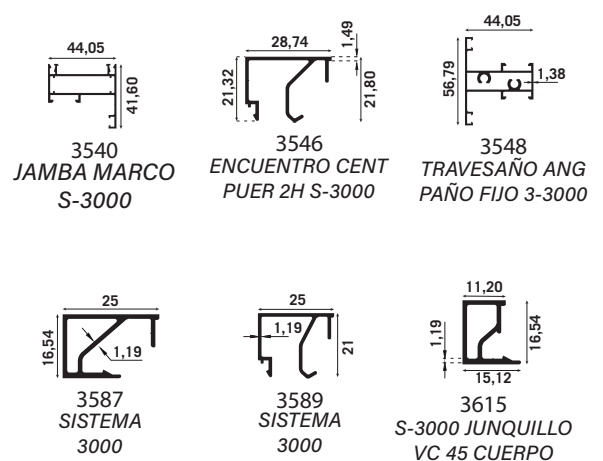

*LAS MEDIDAS DE REFERENCIA DE LAS IMAGENES SON EN MILIMETROS

S3000 VENTANA BATIENTE DOBLE

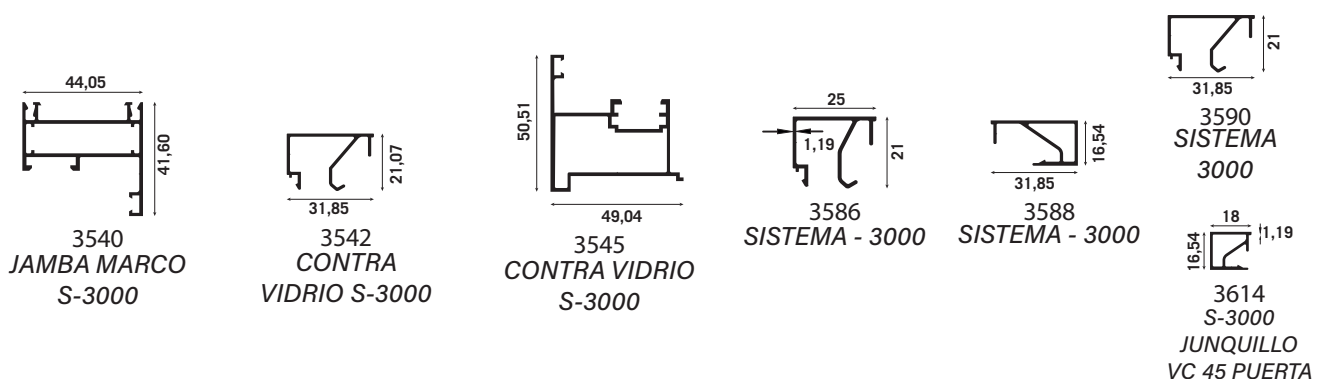

*LAS MEDIDAS DE REFERENCIA DE LAS IMAGENES SON EN MILIMETROS

CARROCERÍAS

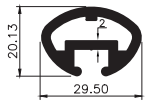

3085
CARROCERIAS

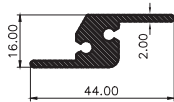

3727
MARCO
DE VENTANA

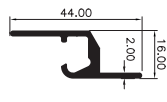

3728
PARANTE
MARCO

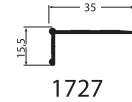

1727
ANGULO
DECORATIVO



1985
HOJA

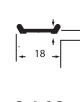

2468
REMATE

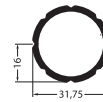

1205
TUBO REDONDO
1 1/4 ESTRIADO

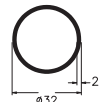

1254
TUBO
REDONDO
1 1/4

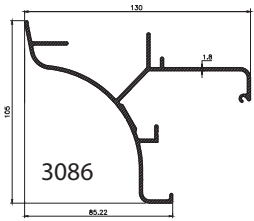

3086
CARROCERIAS

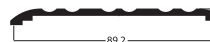

1956
SARDINEL 3 1/2

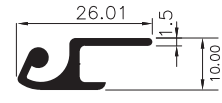

3729
HOJA DE VENTANA

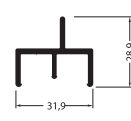

1166
MARCO

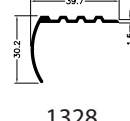

1328
FILO DE
GRADA

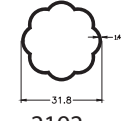

2192
TUBO
PASAMANOS
CARROCERIAS

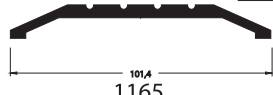

1165
SARDINEL DE 4

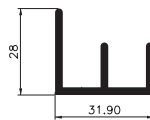

3445
CERCO
VENTANA

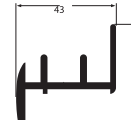

2590
CERCO
CARROCERIAS

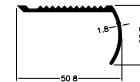

1391
FILO DE
GRADA

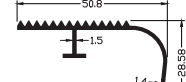

2688
FILO DE
GRADA

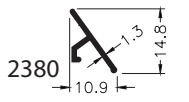

2380
TAPA JUNQUILLO
VIDRIO 10 MM

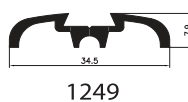

1249
PERFIL CARROCERIAS
MOLDURA

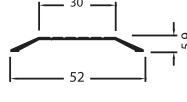

1655
SARDINEL DE 2

CORTINA DE BAÑO

*LAS MEDIDAS DE REFERENCIA DE LAS IMAGENES SON EN MILIMETROS

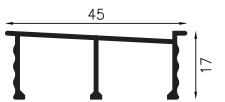

1624
BASE PUERTA BAÑO



1626
HORIZONTAL
SUPERIOR

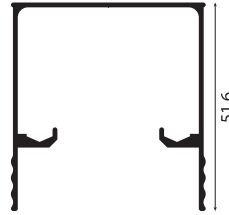

1623
RIEL SUPERIOR



1627
VERTICAL
DE HOJA

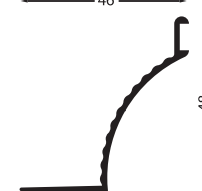

1629
PORTA TOALLERO

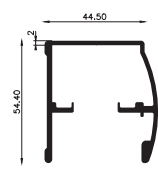

3151
CABEZAL C/B
VIDRIO TEMPLADO

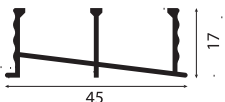

2338
RIEL INFERIOR



1628
HORIZONTAL
INFERIOR



1625
JAMBA MARCO



1630
TOALLERO

CORTINERÍA - PERSIANAS

*LAS MEDIDAS DE REFERENCIA DE LAS IMAGENES SON EN MILIMETROS

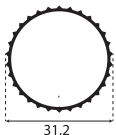

2739
TUBO ESTRIADO
DE 1 1/4

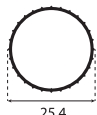

2647
TUBO
ESTRIADO DE 1



1821
PINON
(OCTOPRON)



2738
TUBO
ESTRIADO 1/2



2648
TUBO
ESTRIADO
DE 3/4

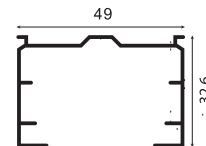

2359
RIEL (OCTOPRON)

VENTANA CORREDIZA SUPER - ECONÓMICA

*LAS MEDIDAS DE REFERENCIA DE LAS IMAGENES SON EN MILIMETROS

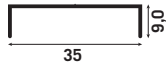

3302

JAMBA V/C
SUPER ECONOMICA

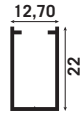

3303

VERTICAL V/C
SUPER ECONOMICA

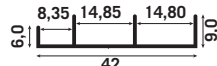

3305

BASE CABEZAL V/C
SUPER ECONOMICA

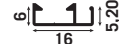

1810

MALLA FIJA
ECONOMICA

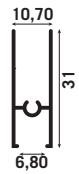

3304

HORIZONTAL V/C
SUPER ECONOMICA

MAMPARA SERIE 100

*LAS MEDIDAS DE REFERENCIA DE LAS IMAGENES SON EN MILIMETROS

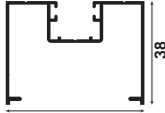

1705

PERIMETRAL FIJO

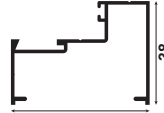

1707

PERIMETRAL MOVIL

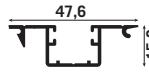

1706

TAPA

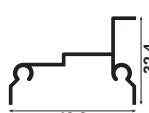

1709

ANCLA

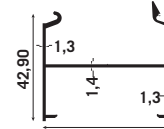

2921

AUMENTO
MAMPARA S100



1824

TAPA LISA



1708

JUNQUILLO

MAMPARA SERIE 200

*LAS MEDIDAS DE REFERENCIA DE LAS IMAGENES SON EN MILIMETROS

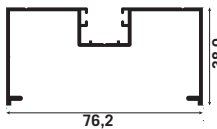

1161

PERIMETRAL FIJO

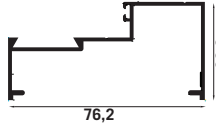

1163

PERIMETRAL MOVIL

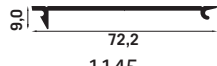

1145

PARANTE TUBULA
DE 35 X 35

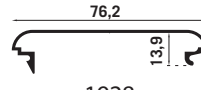

1928

DIVISIONES
INTERIORES RIGHETTI

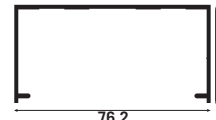

2279

VENTANA CORREDIZA

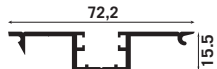

1162

TAPA

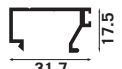

1164

JUNQUILLO

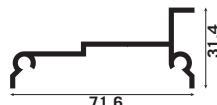

3103

ANCLA

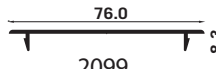

2099

TAPA MAMPARA S 200



3092

JUNQUILLO

VIDRIO 20 MM L/E

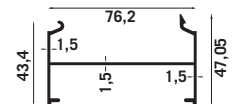

2922

AUMENTO
MAMPARA S 200

MAMPARA SERIE 300

*LAS MEDIDAS DE REFERENCIA DE LAS IMAGENES SON EN MILIMETROS

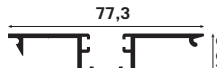

1112

TAPA MAMPARA
4 PULGADAS

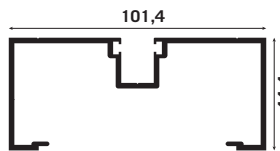

1113

FIJO MAMPARA
4 PULGADAS

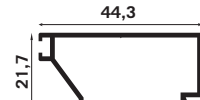

1115

BORDO MAMPARA
4 PULGADAS

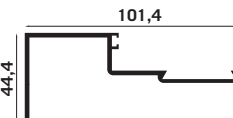

1114

MOVIL MAMPARA
4 PULGADAS

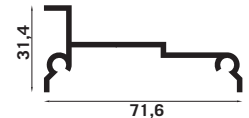

3103

ANCLA

ALFAJÍAS

*LAS MEDIDAS DE REFERENCIA DE LAS IMAGENES SON EN MILIMETROS

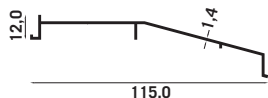

1467

ALFAJIA 4 1/2

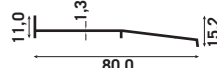

1743

ALFAJIA 3 1/4

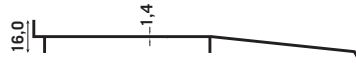

2169

ALFAJIA



2544

ALFAJIA 114 MM

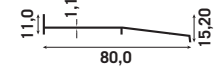

3341

ALFAJIA

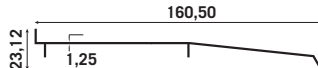

3346

ALFAJIA

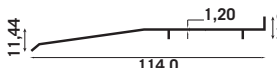

3348

ALFAJIA

*LAS MEDIDAS DE REFERENCIA DE LAS IMAGENES SON EN MILIMETROS

TUBOS CON ALETA

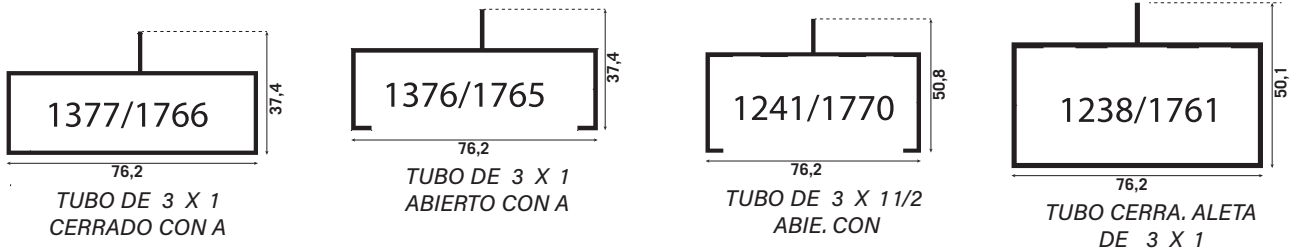

TUBO DE 3 X 1
CERRADO CON A

TUBO DE 3 X 1
ABIERTO CON A

TUBO DE 3 X 1 1/2
ABIE. CON

TUBO CERRA. ALETA
DE 3 X 1

*LAS MEDIDAS DE REFERENCIA DE LAS IMAGENES SON EN MILIMETROS

TUBOS SIN ALETA -CANALES



1773
TUBO DE 3 X 1
AB. SIN ALETA

1769
1240 MODIFICADO

*LAS MEDIDAS DE REFERENCIA DE LAS IMAGENES SON EN MILIMETROS

ESQUINEROS

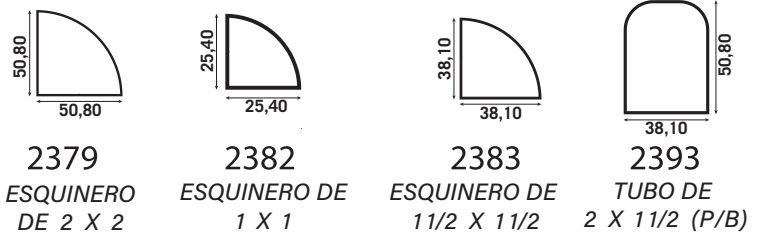

2379
ESQUINERO
DE 2 X 2

2382
ESQUINERO DE
1 X 1

2383
ESQUINERO DE
1 1/2 X 1 1/2

2393
TUBO DE
2 X 1 1/2 (P/B)

TUBOS RECTANGULARES

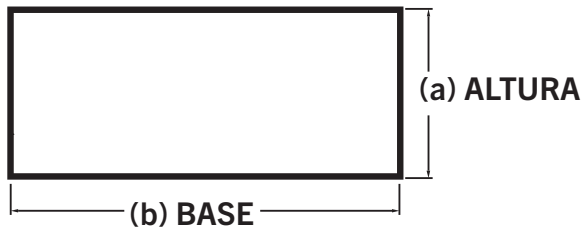

REFERENCIA	BASE (B)		ALTURA (A)		ESPESOR (mm)
	MILIMETROS	PULGADAS	MILIMETROS	PULGADAS	
1009 / 1507	101.6	4	44.4	1 3/4	2.40
1016 / 1853	50.8	2	38.1	1 1/2	1.40
1239 / 1762	76.2	3	38.1	1 1/2	1.40
1772	76.2	3	25.40	1	1.45
2027	74.00	2 29/32	24.00	15/16	1.20
2289	38.1	1 1/2	19.05	3/4	1.15
2601	101.6	4	38.1	1 1/2	1.50
2857	50.8	2	25.4	1	1.00

*LAS MEDIDAS DE REFERENCIA DE LAS IMAGENES SON EN MILIMETROS

TUBOS REDONDOS

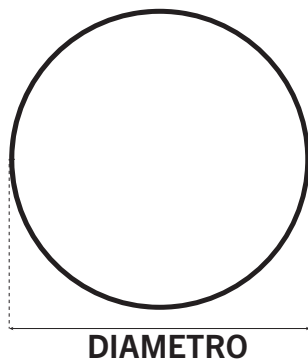

DIAMETRO
TUBO REDONDO

REFERENCIA	DIAMETRO		ESPESOR (mm)
	MILIMETROS	PULGADAS	
1012	50.8	2	1.27
1013	76.20	3	1.27
1157	17.9	45/64	1.07
1158	23.40	59/64	1.24
1167	101.60	4	1.27
1168	127.00	5	1.50
1169	152.40	6	1.65
1204	25.40	1	2
1600	90.00	3 35/64	4.50
1665	48.23	1 29/32	2.75
1666	48.23	1 57/64	3.67
1668	19.10	3/4	1.50
2151	15.70	5/8	1.21

*LAS MEDIDAS DE REFERENCIA DE LAS IMAGENES SON EN MILIMETROS